

THIS DOCUMENT REMAINS PROPERTY OF ITEQ ENGINEERING B.V. NO PARTS OF THIS DOCUMENT MAY BE REPRODUCED OR TRANSMITTED IN ANY FORM OR BY ANY MEANS, ELECTRONIC OR MECHANIC (INCLUDING PHOTOCOPYING), FOR ANY PURPOSE WITHOUT THE WRITTEN CONSENT OF ITEQ ENGINEERING B.V.

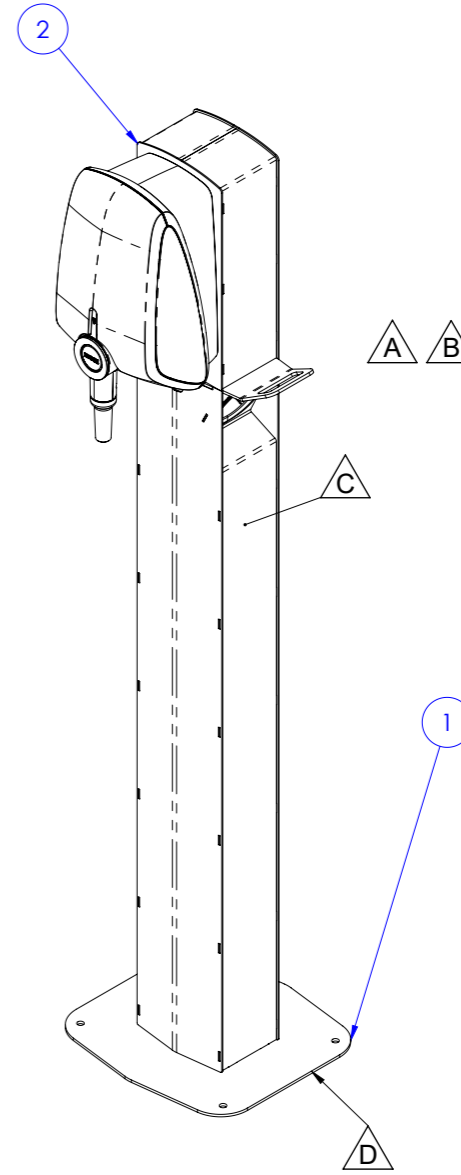
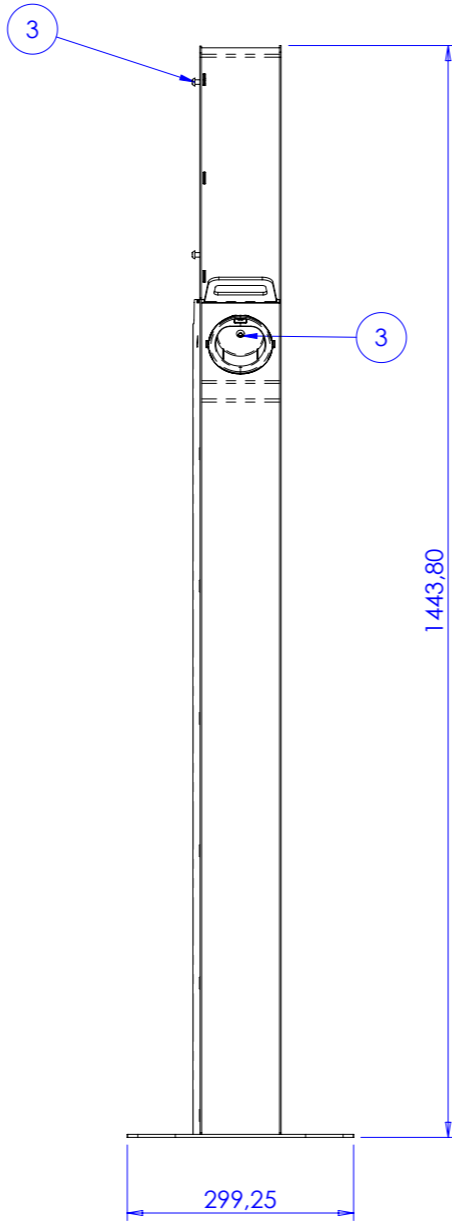
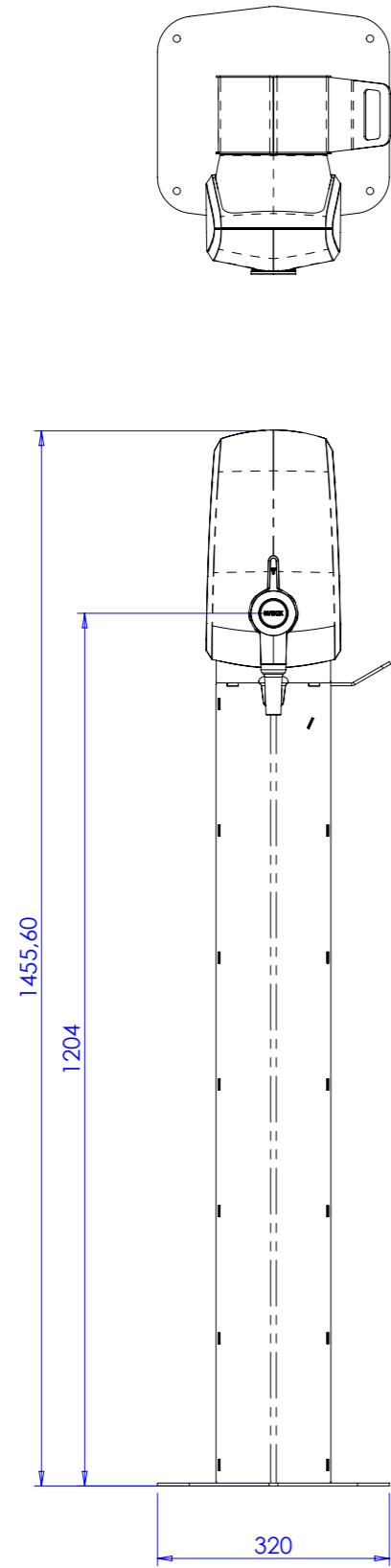

UNSPECIFIED TOLERANCES ACC TO: ISO 2768 - M

| Limits for linear measures | | | | | | | | |
|----------------------------|--------|--------|-------|--------|-------|-------|-------|------|
| From | 0.5 | 3 | 6 | 30 | 120 | 400 | 1000 | 2000 |
| Up to | 3 | 6 | 30 | 120 | 400 | 1000 | 2000 | 4000 |
| F (fine) | ± 0.05 | ± 0.05 | ± 0.1 | ± 0.15 | ± 0.2 | ± 0.3 | ± 0.5 | - |
| M (medium) | ± 0.1 | ± 0.1 | ± 0.2 | ± 0.3 | ± 0.5 | ± 0.8 | ± 1.2 | ± 2 |
| C (coarse) | ± 0.15 | ± 0.2 | ± 0.5 | ± 0.8 | ± 1.2 | ± 2 | ± 3 | ± 4 |
| V (very coarse) | - | ± 0.5 | ± 1 | ± 1.5 | ± 2.5 | ± 4 | ± 6 | ± 8 |

| Limits for angular dimensions | | | | | |
|-------------------------------|---------|-------|-------|-------|-------|
| From | 0 | 10 | 50 | 120 | 400 |
| Up to | 10 | 50 | 120 | 400 | -- |
| F (fine) | ± 1' | ± 30' | ± 20' | ± 10' | ± 5' |
| M (medium) | ± 1' | ± 30' | ± 20' | ± 10' | ± 5' |
| C (coarse) | ± 1'30' | ± 1' | ± 30' | ± 15' | ± 10' |
| V (very coarse) | ± 3' | ± 2' | ± 1' | ± 30' | ± 20' |

| REVISIONS | | | |
|-----------|----------------------------------|-----------|----------|
| REV. | DESCRIPTION | DATE | APPROVED |
| A | Pole changed after review | 30-1-2018 | TR |
| B | Pole changed after intern review | 14-3-2018 | TR |
| C | Part IEP-020644 changed | 4-5-2018 | TR |
| D | Part IEP-020695 changed | 22-5-2018 | TR |

| IT. | QTY | PART NUMBER | REV | DESCRIPTION | CATEGORY | MATERIAL |
|-----|-----|-------------|-----|--|------------------------|-------------------------|
| 1 | 1 | IEA-005006 | D | WELD ASSY - E-BOX COLUMN | Welding part / assy | - |
| 2 | 1 | IEP-020648 | B | PLATE | Sheetmetal part / assy | RVS 304 1.4301 EN1088-2 |
| 3 | 5 | M6 | - | M6 hexalobular socket button head - Fabory - 51029060022 | Purchasing part | RVS 304 1.4301 EN1088-2 |



evbox.com
support@evbox.com

THIRD ANGLE PROJECTION



DESCRIPTION:

MAIN ASSY - ELVI-POLE

DRAWING NR.:

IEA-005010

CUSTOMER REF.:

REV.:

D

SURFACE: 3.02 M²

WEIGHT: 17.04 KG

UNITS:MM

SCALE:1:10

PAGE 1 OF 1

PAPER SIZE: A3